

BACK VIEW

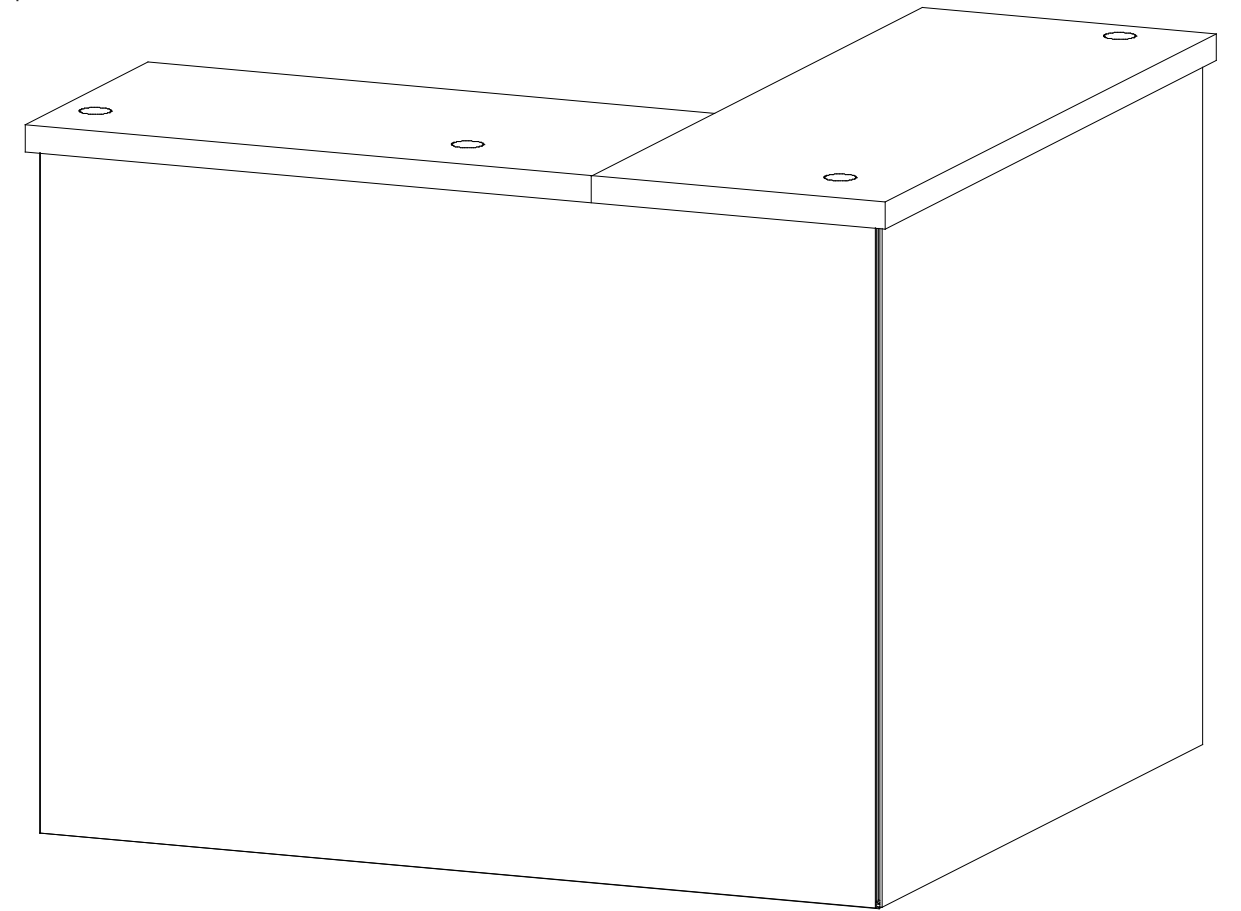

FRONT VIEW

SETUP INSTRUCTIONS

General Setup Instructions

- Read entire setup instruction manual prior to unpacking parts and pieces.
- The setup instructions are created specifically for this configuration.
- Setup instructions are laid out sequentially in steps, including exploded views with detailed explanation for assembly.

Cleaning & Packing

- For Cleaning Metal, Plex, & Laminate Parts: Use a **MILD NON-ABRASIVE** cleanser and soft cloth/paper towel to clean all surfaces.
- Keep exhibit components away from heat and prolonged sun exposure. **Heat and UV exposure will warp and fade components.**
- Retain all provided Packing Materials. All provided packing materials are for ease of repacking & component protection.

Disassembly

- For loss prevention, tighten all set screws and locks during disassembly.

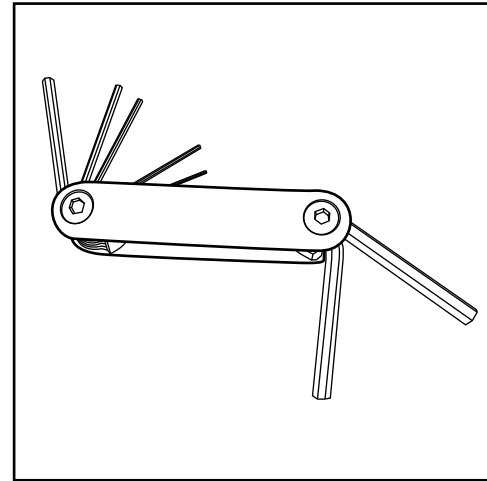

Hex Tool - Essential for Assembly

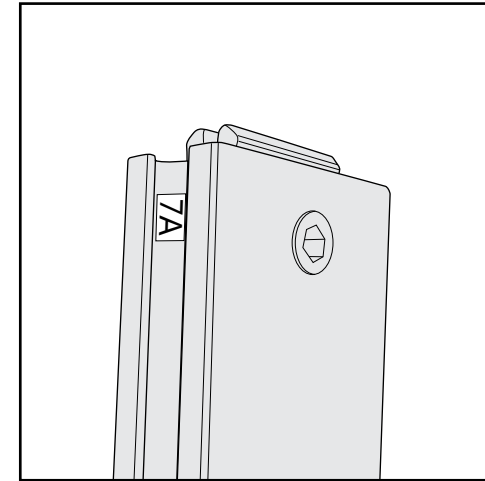

Part Identification - Numbering

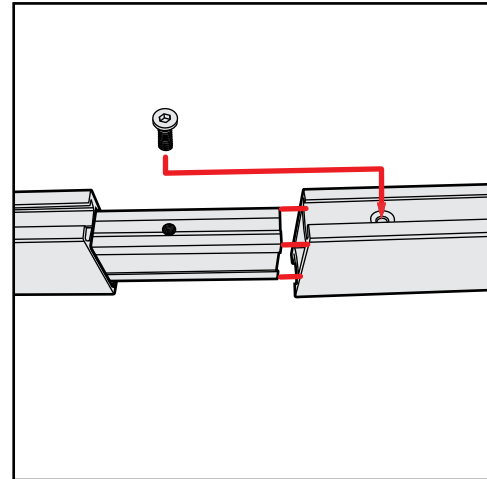

Spline Connection

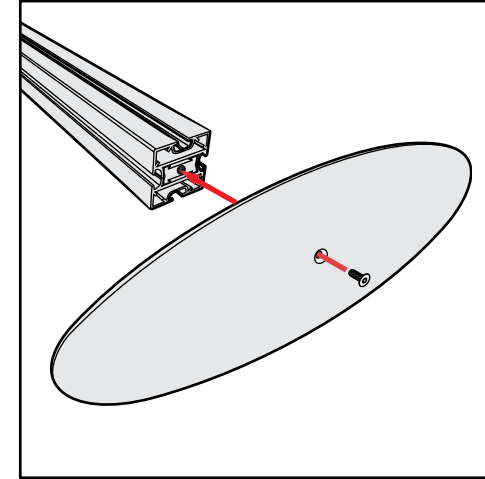

Base Plate & Extrusion Connection

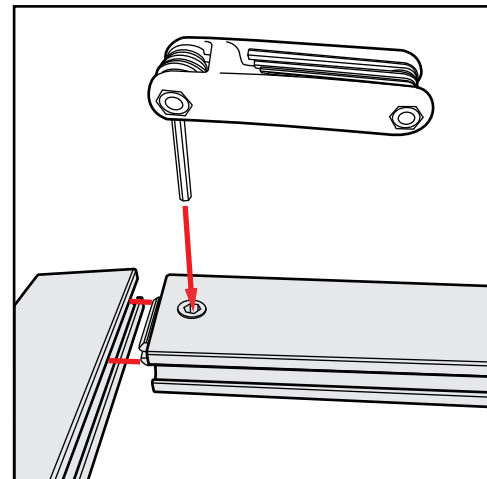

Extrusion & Lock Connection

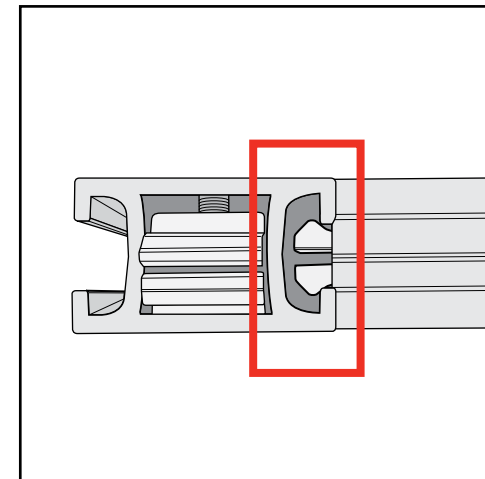

Engaged Lock



WARNING

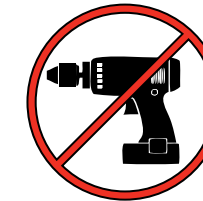

DO NOT USE POWER TOOLS



LADDERS OR LIFTS
MAY BE REQUIRED



ALL CONNECTIONS MUST
BE TIGHTLY SECURED

Straight Connection

When assembling frame, first attach all **straight connectors**, then attach **corner connectors**.

- 1) Place extrusions end-to-end.
- 2) Loosen all knobs, then slide **straight connectors** across the seam of extrusions.
- 3) Tighten all knobs to secure connection.

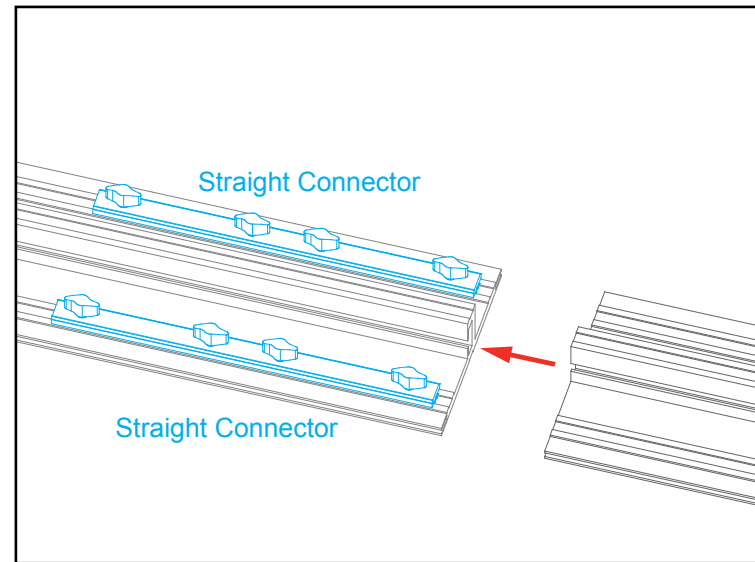

Slide both connectors across seam of extrusions. Tighten all knobs.

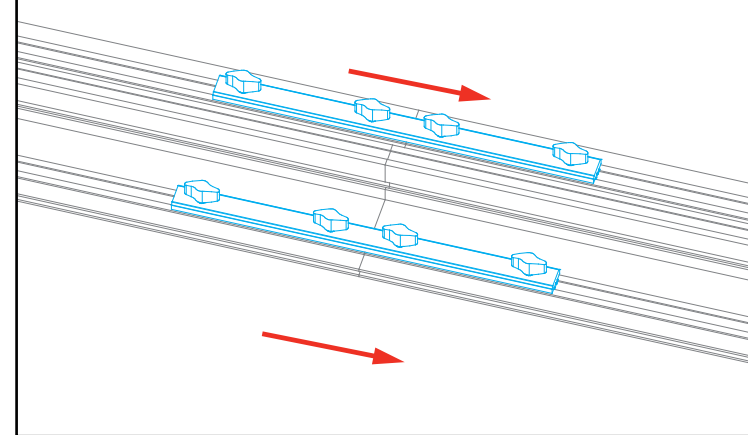

All knobs must be tightened securely to ensure a proper connection.

Disassembly

- 1) Loosen all knobs.
- 2) Slide connectors off of one extrusion.
- 3) Tighten knobs to prevent loss during packing & shipping.

Keep straight connectors in groove of extrusion. Do not remove connectors during disassembly.

Corner Connection

- 1) Loosen knobs, then slide vertical extrusions onto **corner connectors** of **lower** horizontal extrusion.
- 2) Slide **corner connectors** of **upper** horizontal extrusion into grooves of vertical extrusions.
- 3) Tighten all knobs to secure connection.

Disassembly

- 1) Loosen knobs on vertical extrusions.
- 2) Slide the vertical extrusions off of **corner connectors** on lower and upper horizontal extrusions.

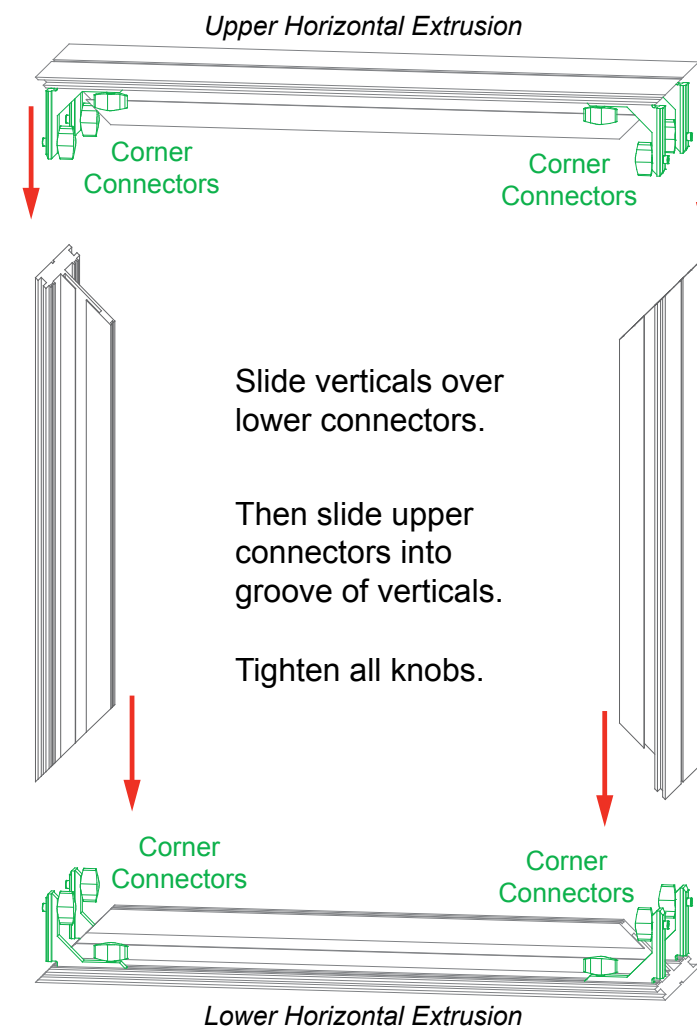

Slide verticals over lower connectors.

Then slide upper connectors into groove of verticals.

Tighten all knobs.



Adjust connectors if necessary to prevent gaps in connection.

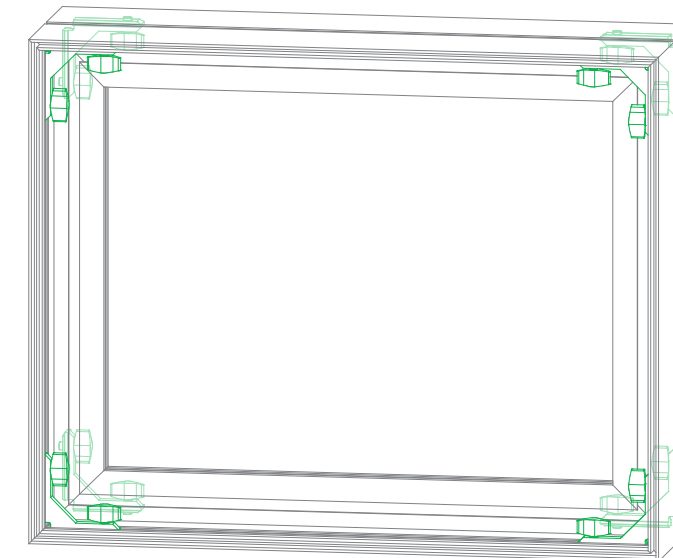

COMPLETED ASSEMBLY

All knobs must be tightened securely to ensure a proper connection.

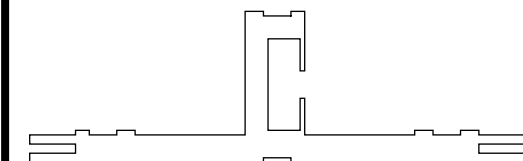

CEI152 Profile

The Perfect Fit

SEG Graphic Installation *in 3 Steps*

STEP 1: Attach Corners

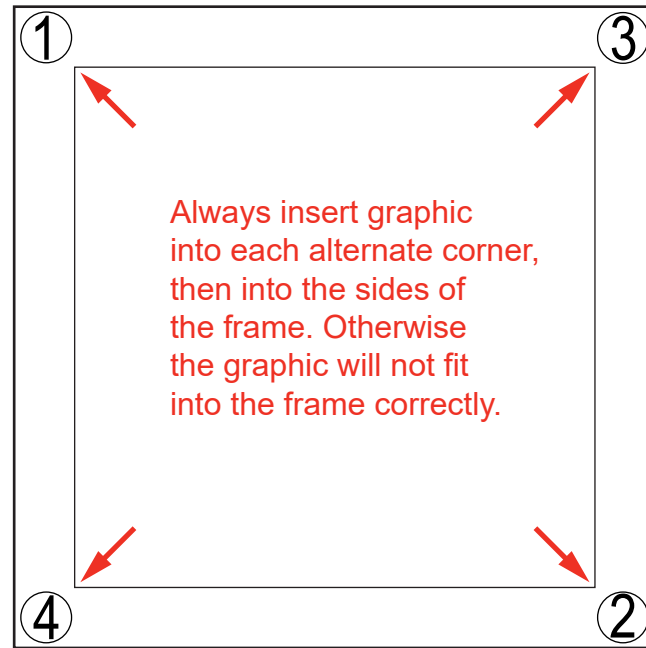

STEP 2: Attach Middle

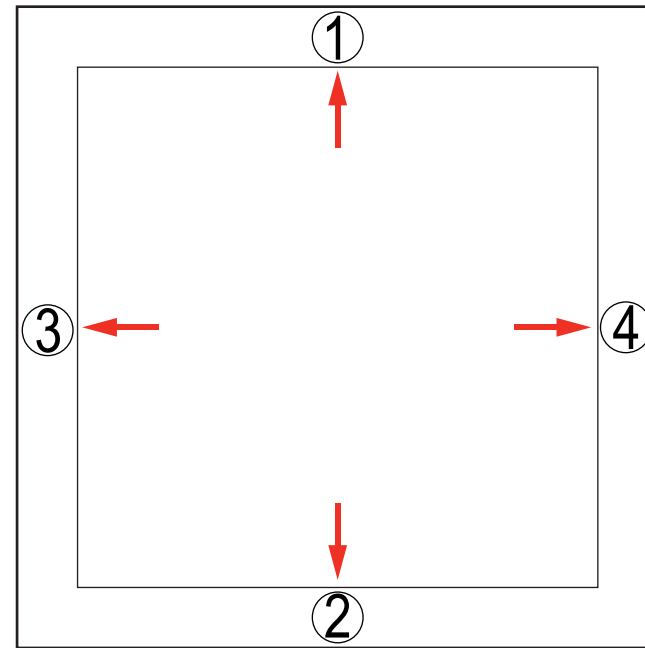

STEP 3: Attach Sides

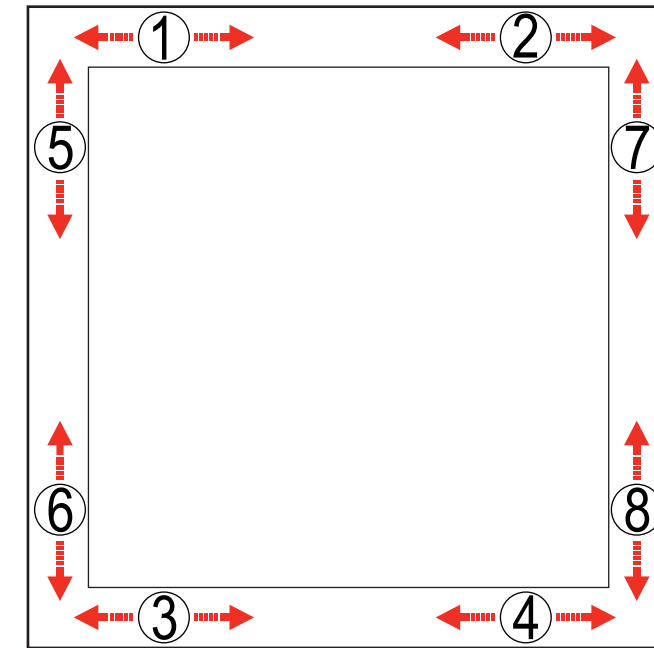

Insert narrow side of silicone welt into the channel at corner 1, with fabric to the outside.

Repeat for opposite corner 2, then corner 3, then corner 4.

Once corners are attached, press the middle of edge 1 into the channel. Then press middle of edge 2 into the channel on opposite side.

Repeat with edge 3 & 4.

Once the middle of sides are attached, fully press the silicone welt into the channel, between center and corner at location 1. Repeat the process between center and corner at location 2.

Do the same for welt on opposite side, at locations 3 & 4. Then repeat for locations 5 & 6 and 7 & 8.

Once the welt is fully inserted on all sides, smooth out edges as needed for a perfect fit.



To remove the graphic from the frame, locate the fabric **pull tab**. Gently pull on the tab to remove the graphic.

Install video:



Top View of Each Level

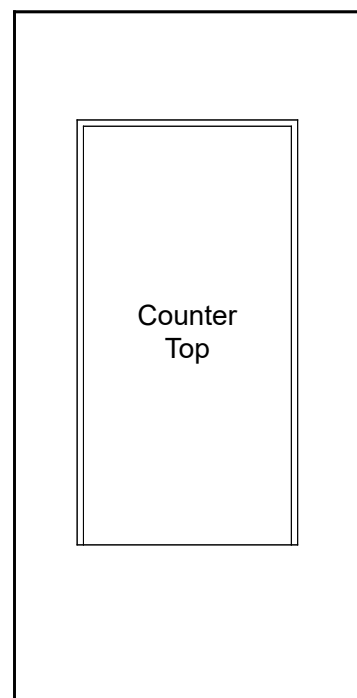

Level 1
(Bottom level)

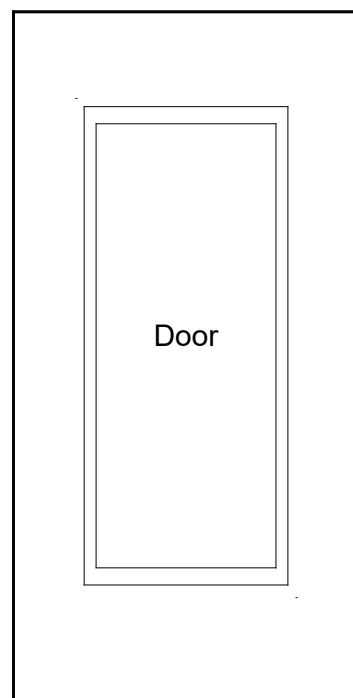

Level 2

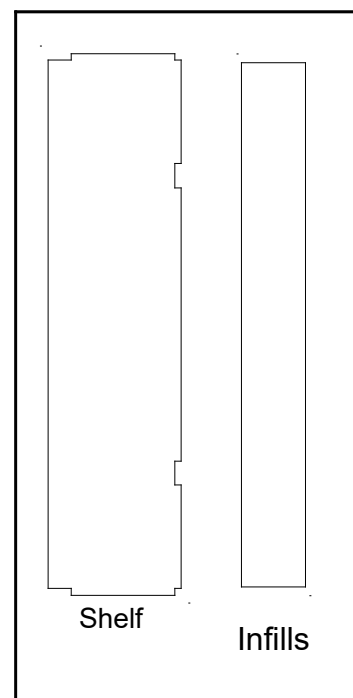

Level 3

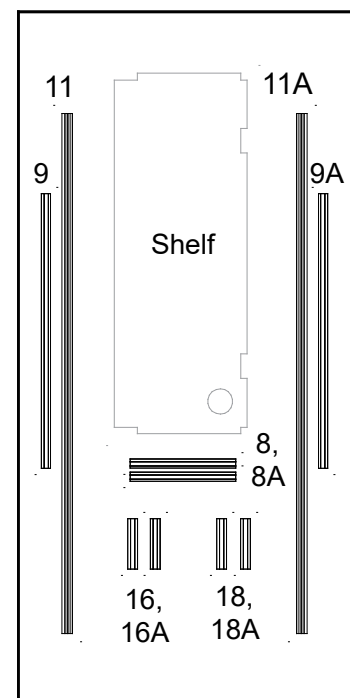

Level 4

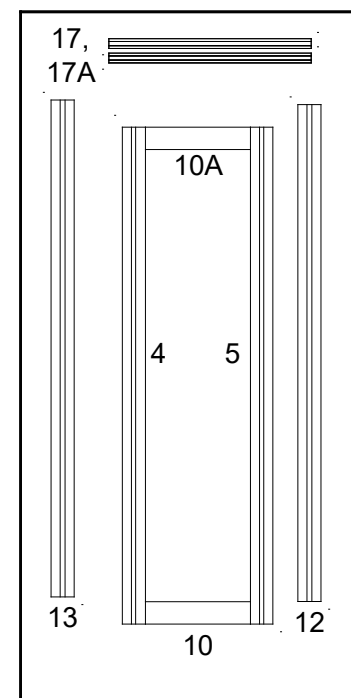

Level 5

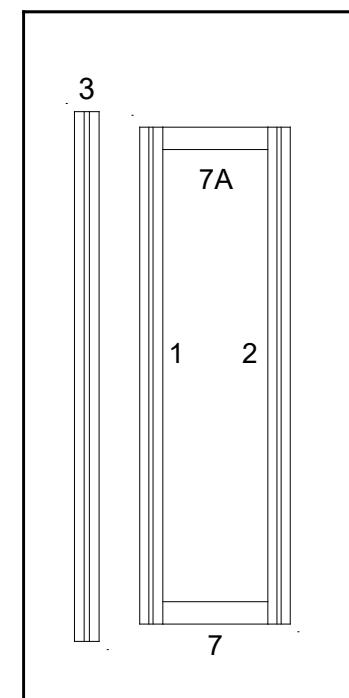

Level 6

Top View of Each Level

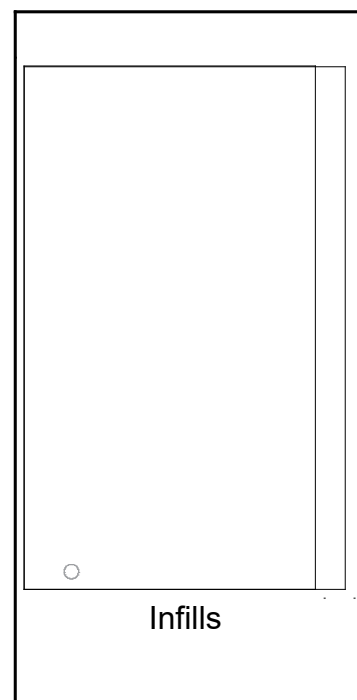

Level 1
(Bottom level)

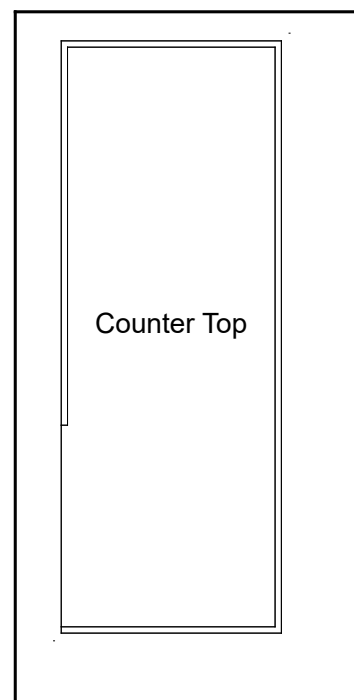

Level 2

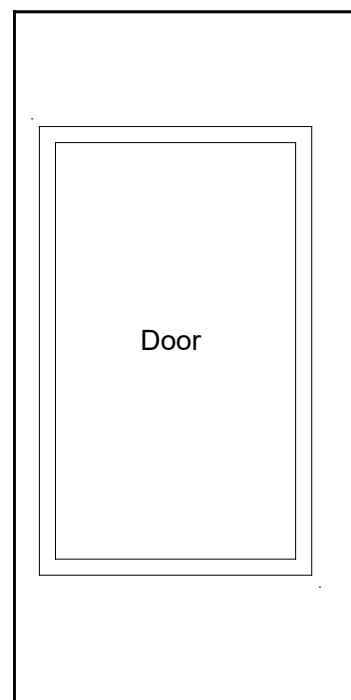

Level 3

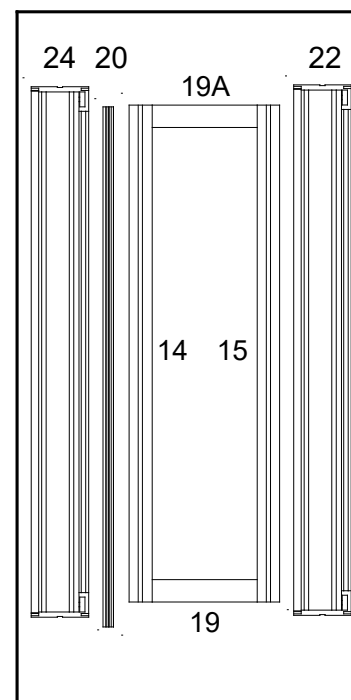

Level 4

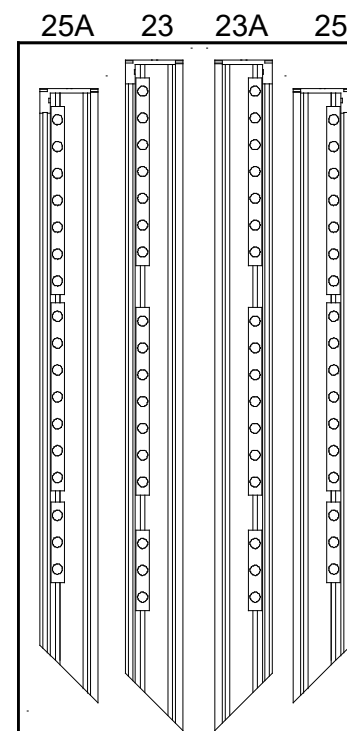

Level 5

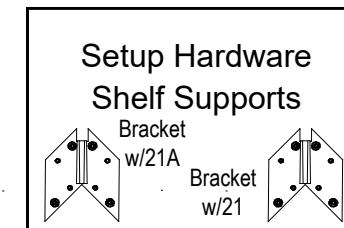
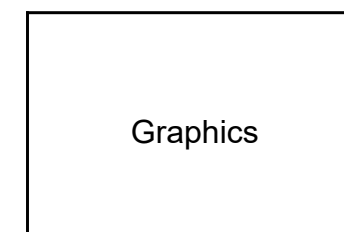

Item	Qty.	Description
1	1	39.5" S44 Vertical Extrusion
2	1	39.5" S44 Vertical Extrusion
3	1	39.5" S44 Vertical Extrusion
4	1	39.5" S44 Vertical Extrusion
5	1	39.5" S44 Vertical Extrusion
7,7A	1,1	8.341" Z45 Horizontal Extrusion
8,8A	1,1	8.341" Z45 Horizontal Extrusion
9,9A	1,1	21.825" Z45 Horizontal Extrusion
10,10A	1,1	8.341" Z45 Horizontal Extrusion
12	1	39.5" S44 Vertical Extrusion
13	1	39.5" S44 Vertical Extrusion
14	1	39.5" S44 Vertical Extrusion
15	1	39.5" S44 Vertical Extrusion
16,16A	1,1	4" Z45 Horizontal Extrusion
17,17A	1,1	16.067" Z45 Horizontal Extrusion
18,18A	1,1	4" Z45 Horizontal Extrusion
19,19A	1,1	8.341" Z45 Horizontal Extrusion

Steps:

- 1) Assemble lower horizontals [7,8,9,10] between verticals [1,2,3,4,5].
- 2) Slide **Infills** between verticals as shown.
- 3) Attach upper horizontals [7A,8A,9A,10A], securing **infills**.
- 4) Connect lower horizontals [16,17,18,19] between verticals [4,12,13,14,15].
- 5) Slide **Infills** between verticals.
- 6) Secure **Infills** with upper horizontals [16A,17A,18A,19A].
- 7) Connect doors to vertical [3] and [13]. See **Door Connection** detail.

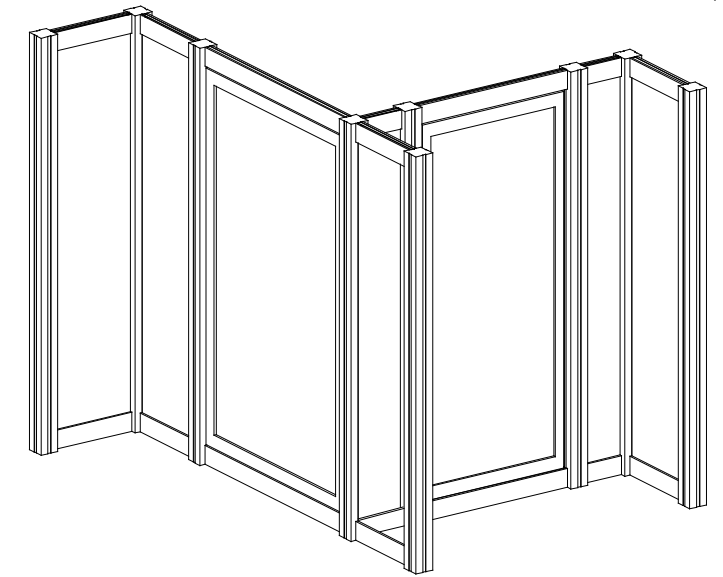

When assembled

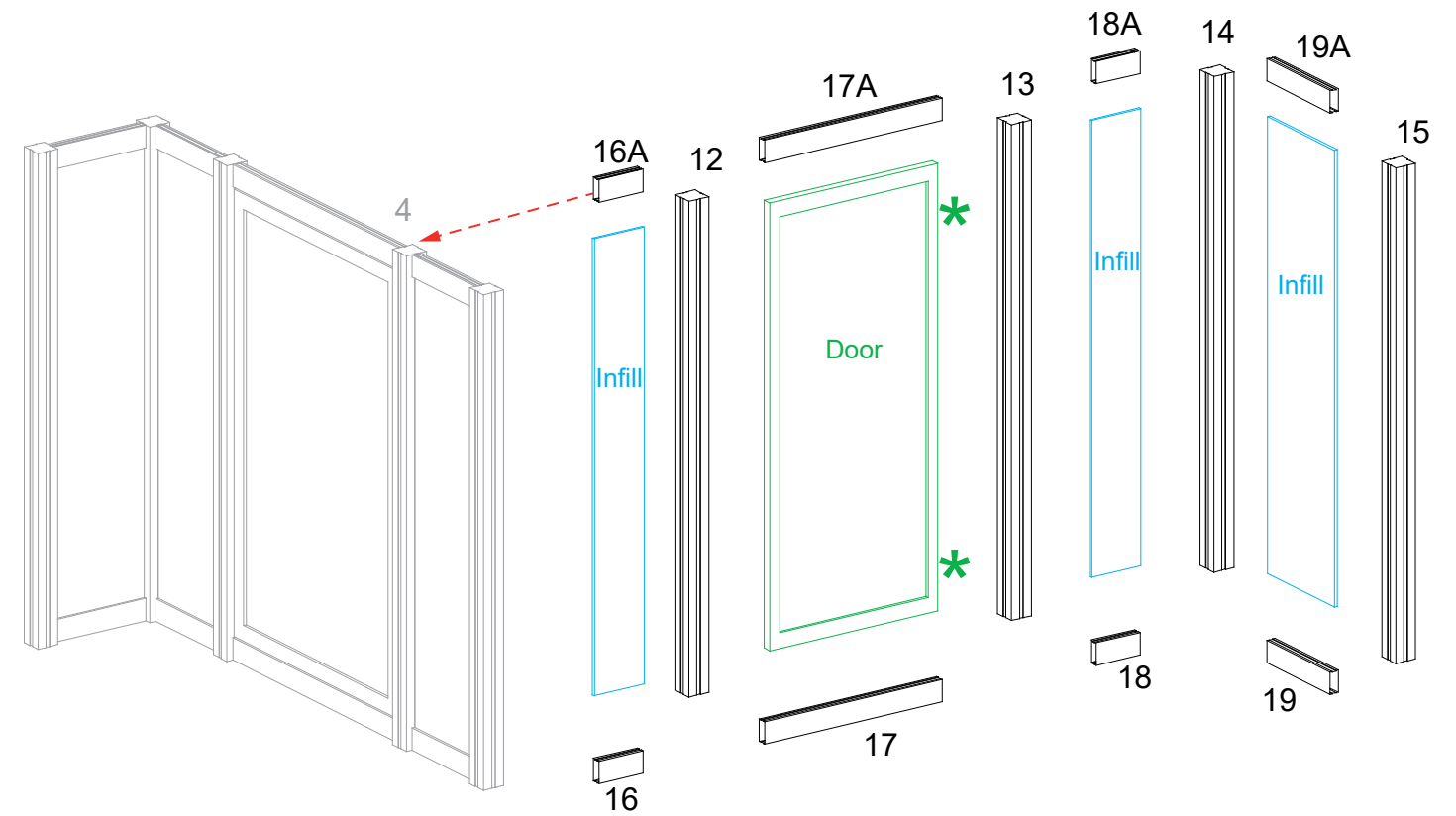
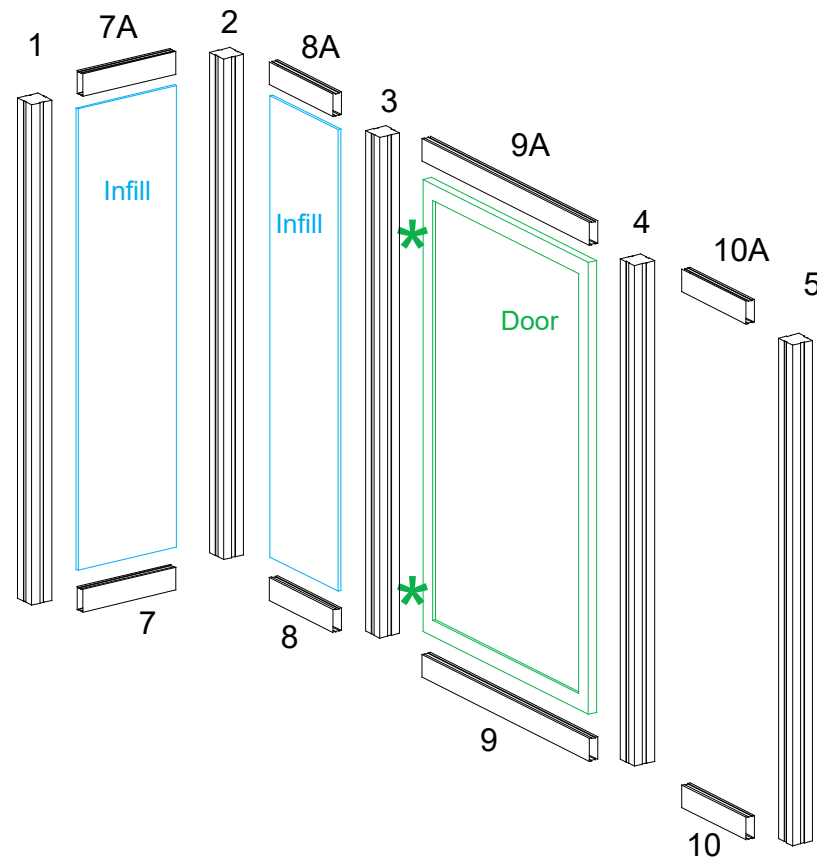
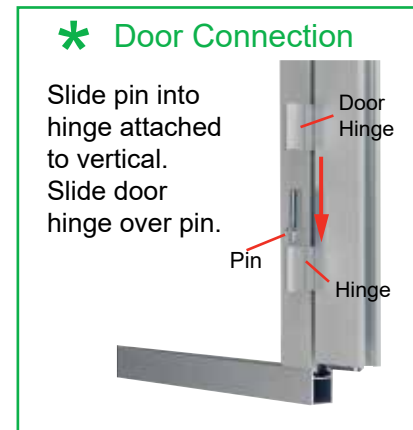

Item	Qty.	Description
11,11A	1,1	35.853" h Z33 Vertical Extrusion
20	1	38.752" TSP2 Vertical Extrusion
21,21A	1,1	3.193" Z31 Horizontal Extrusion
22	1	39.5" CEI110 Vertical Extrusion
23,23A	1,1	45.75" CEI110 Horizontal Extrusion
24	1	39.5" CEI110 Vertical Extrusion
25,25A	1,1	50.037" CEI110 Horizontal Extrusion

Steps:

- 1) Connect horizontals [23] and [23A] to vertical [22] and horizontals [25] and [25A] to vertical [24] See CEI110 Frame Assembly sheet for instruction.
- 2) Attach assembled frames to verticals [1] and [15], as shown. See **Frame to Assembly Attachment** detail.
- 3) Slide 2-part **Infills** into back of both assembled CEI110 frames & secure with verticals [11] & [11A].
- 4) Assemble horizontals [21,21A] & two brackets to vertical [20], then attach brackets to CEI110 corners [23/25] & [23A/25A], inserting **Infill**. See **Z45 & Bracket Connection** detail.

*** Frame to Assembly Attachment**

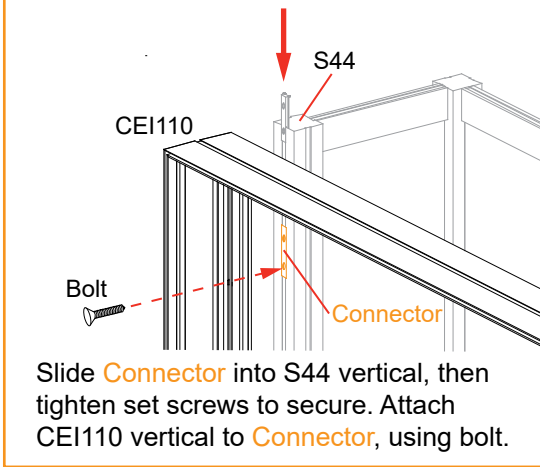

*** Z31 & Bracket Connection**

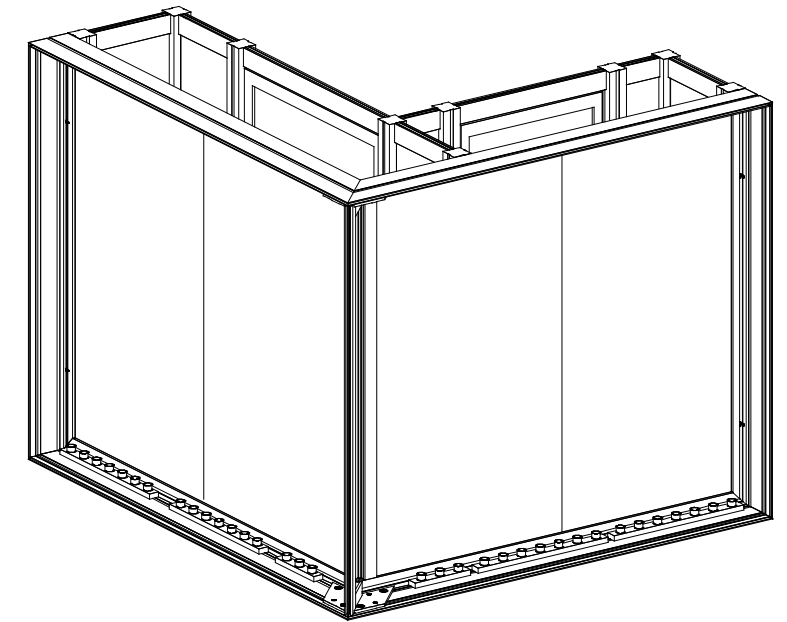
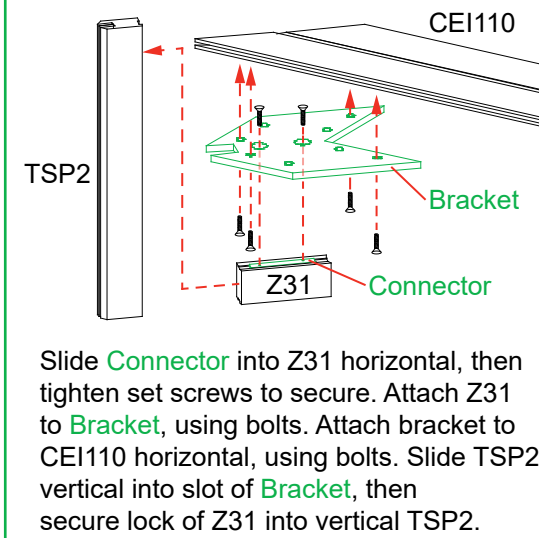

When assembled

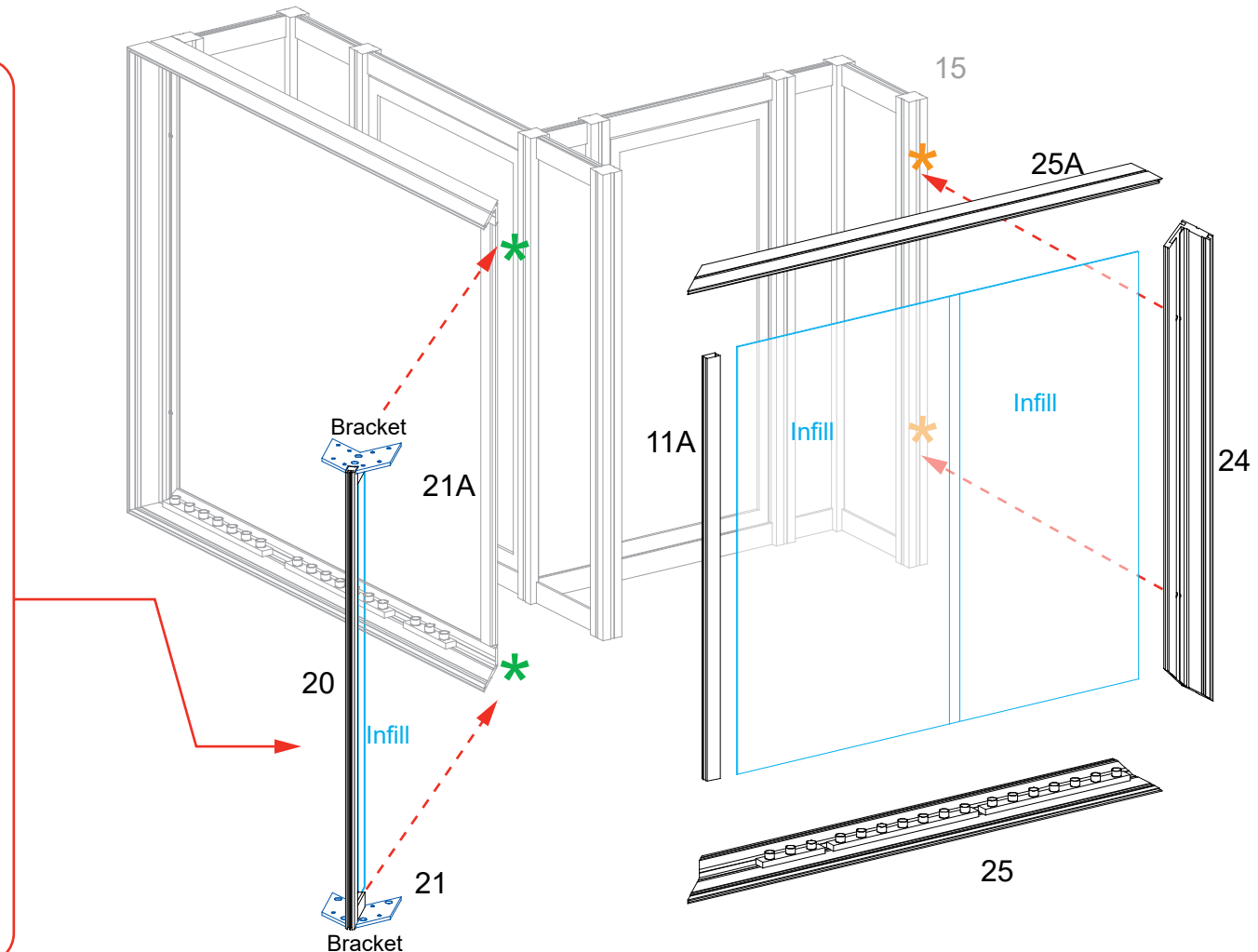
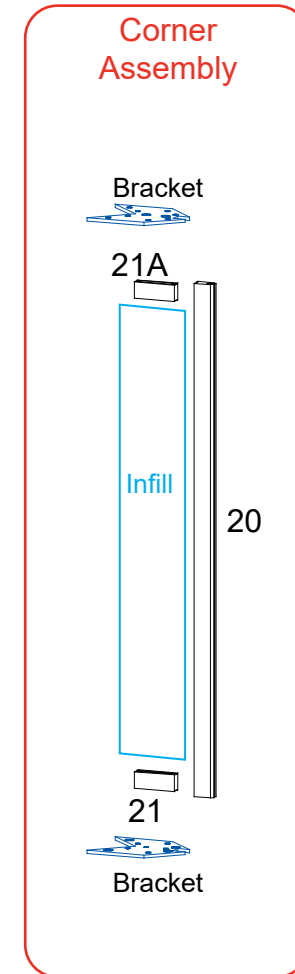
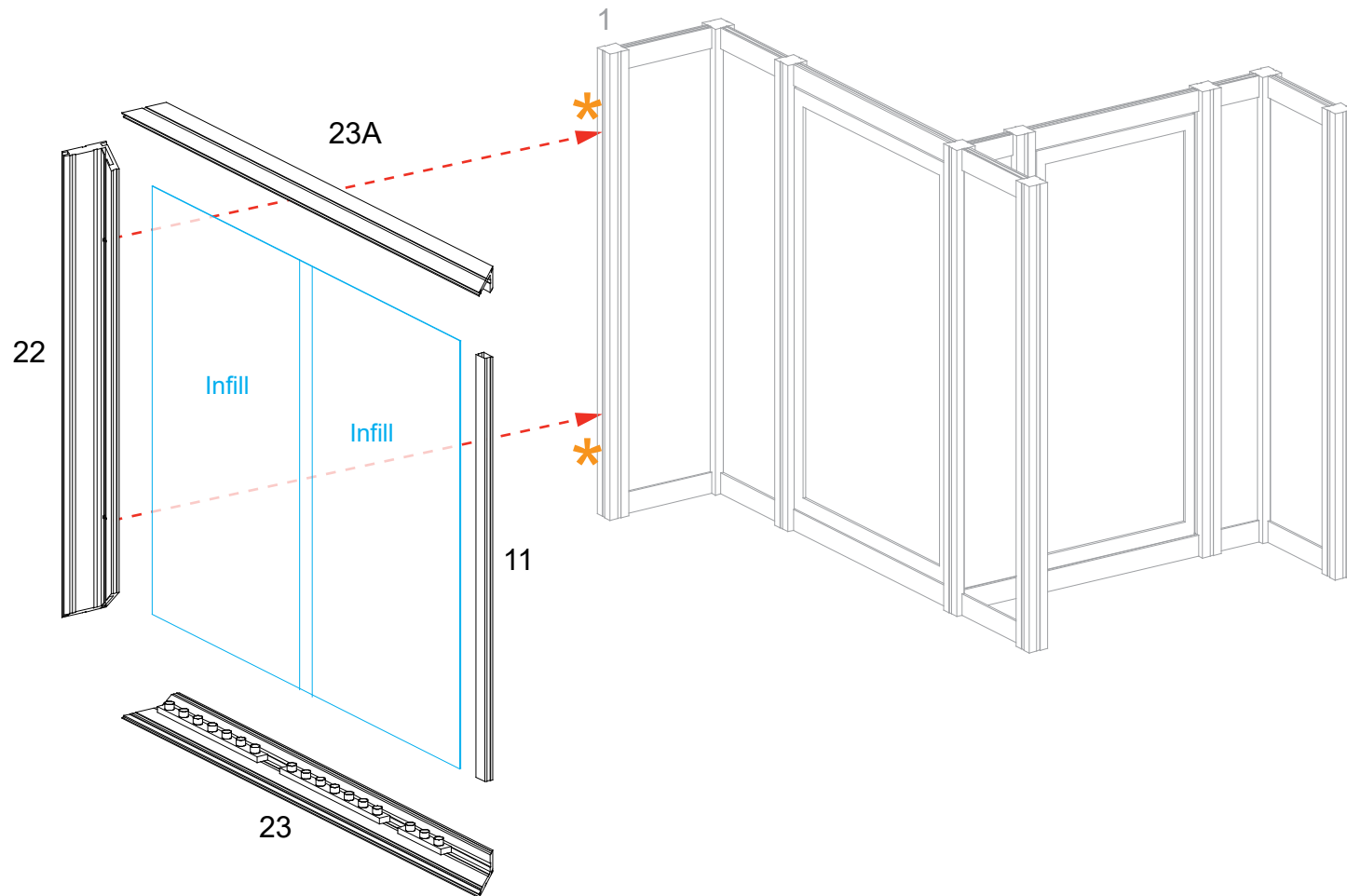

Steps:

- 1) Connect lighting power cords and attach transformers. See [Light to Light Connection](#) and [Light to Transformer Connection](#) details.
- 2) Place shelves onto pins. See [Shelf Pin](#) detail.
- 3) Install SEG graphics to front of assembled frames. Refer to the [SEG Installation general information page](#).
- 4) Place counter top on top of assembled counter base. See [Counter Top Attachment](#) detail.
- 5) Connect power cords to chargers in counter top.

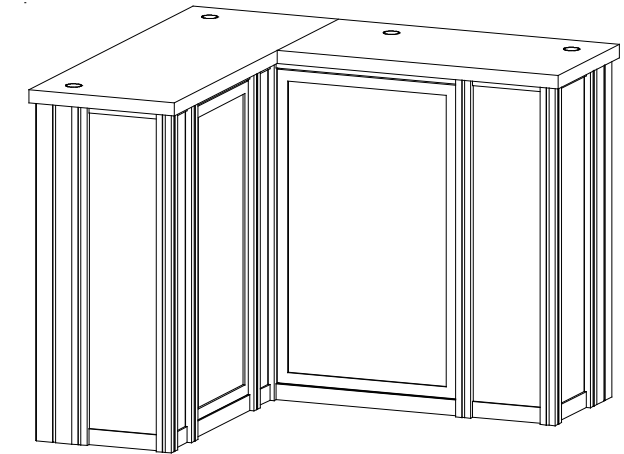
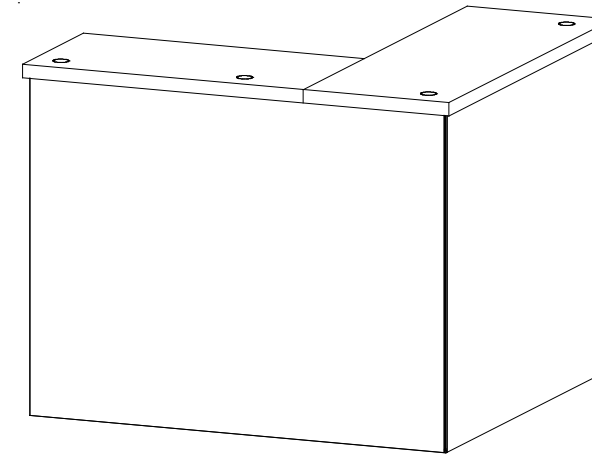
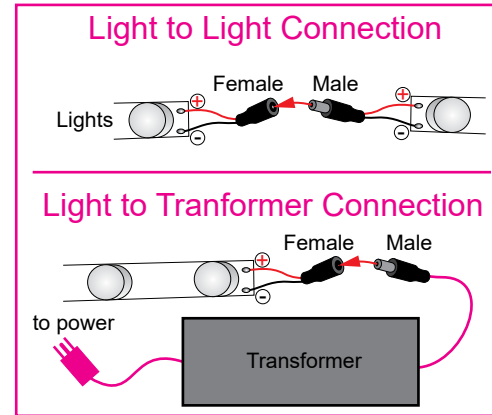

Completed Assembly

* Counter Top Attachment

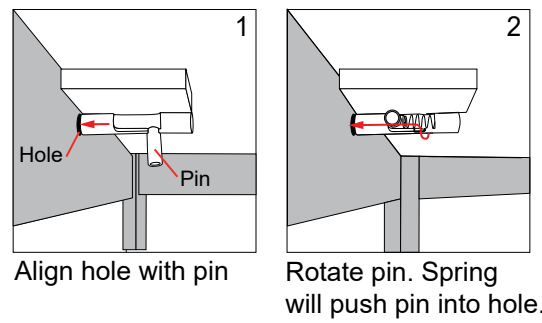

* Shelf Pin

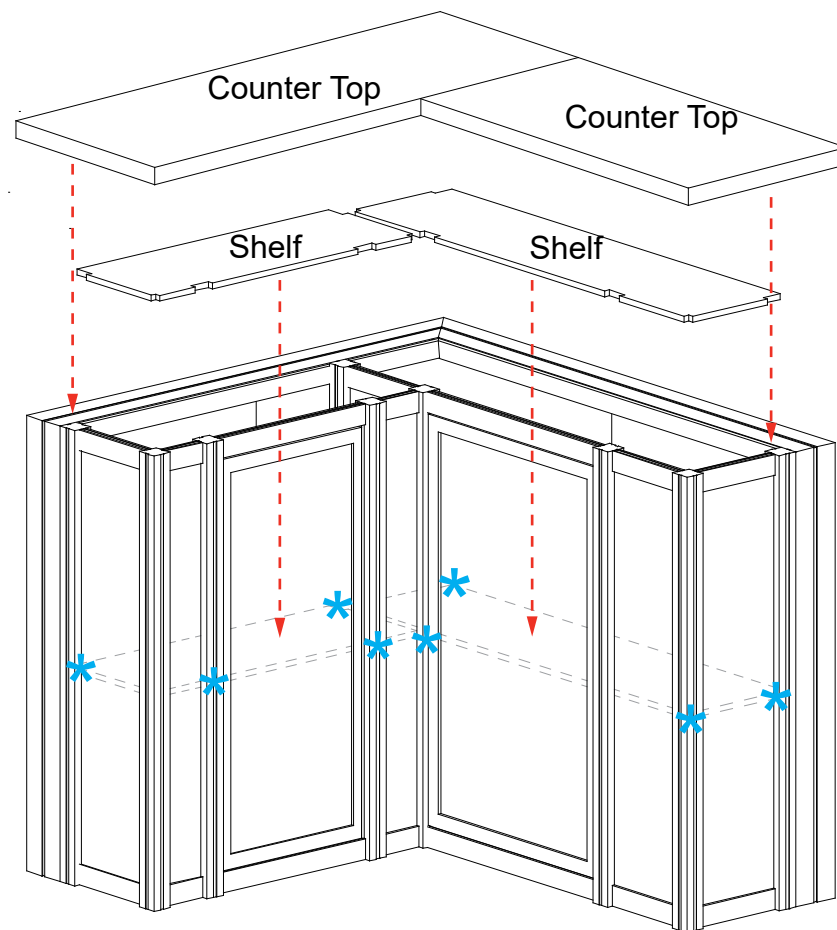
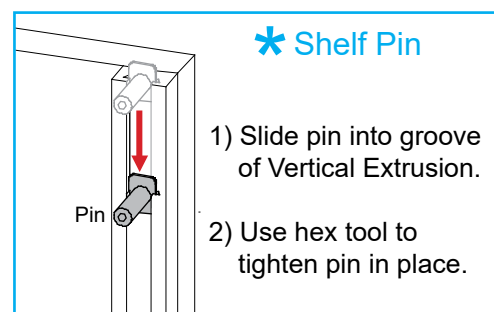

BACK VIEW

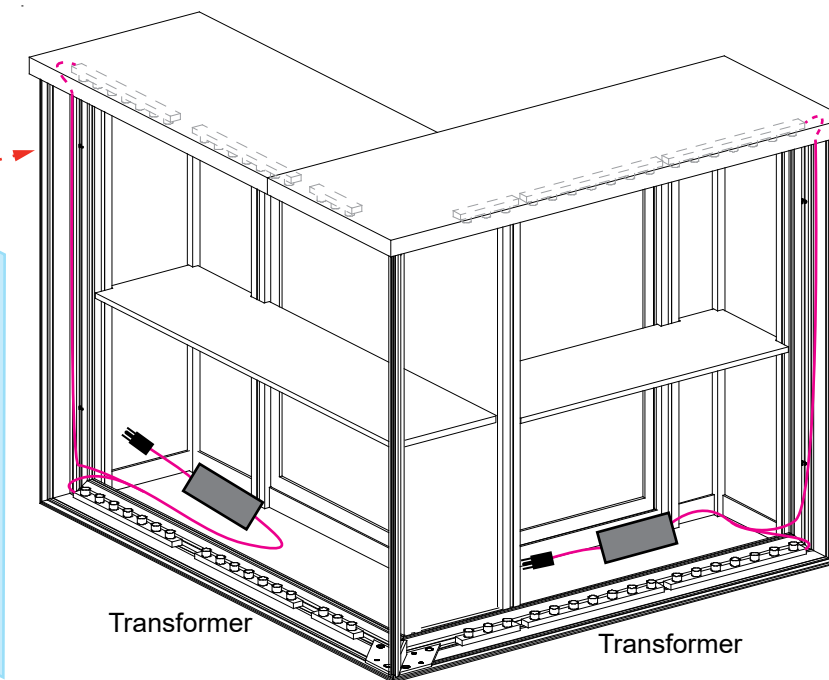
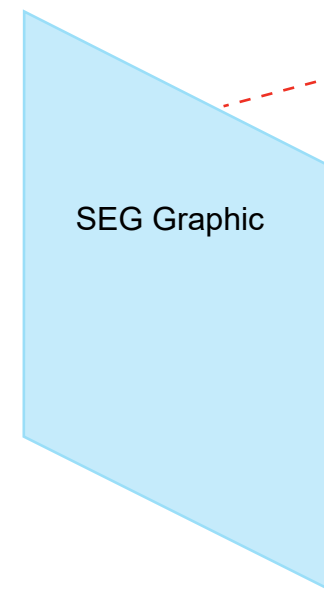

FRONT VIEW

